

Increasing the Production of 3-Chloro-1-Propene (Allyl Chloride) in Unit 600 - Revisited

Background

The problems at the Alabama facility continue. Upon closing down the facility, in order to address the problems of the emissions from the allyl chloride unit, some other problems were found. These problems will require some extensive maintenance work. In addition, some of the equipment has been damaged due to exceeding design pressures while operating the plant well above design conditions. It is expected that the plant will be down between 6 months and 1 yr.

Our company has significant contractual obligations to supply allyl chloride to our customers and it has been determined that the production of allyl chloride at the Beaumont facility **must** be increased to 50% over design capacity, as soon as possible. Your previous recommendations regarding increasing production were well received by management. Upon increasing the throughput by 30%, it was found that the Dowtherm A™ Loop was operating at its maximum capacity, i.e., both pumps operating in parallel and cooling water flow increased by 75%. With the reactor temperature unchanged, it was found that the flow of crude allyl chloride to the separations section could be delivered at a pressure of 2.1 bar and a temperature of approximately 54°C (with a 75% increase in cooling water flow to E-603 and an appropriate increase in the steam make in E-602). The slight increase in temperature of the crude allyl chloride caused some minor problems in the separation section which were consequently remedied. As a result, it has been determined that for a 50% increase in crude allyl chloride production, the feed to the separation section must not exceed 50°C and must be delivered at a minimum pressure of 2.5 bar (This is the pressure which will permit the increased material to flow through the separations section.)

It is recognized that, in order to process this increased throughput at the Beaumont facility, some capital investment will be required. However, since the Alabama plant is expected to come back on line in the future, the capital investment for changes to the Beaumont Facility should be kept to a minimum consistent with the increased throughput. It is also recognized that if a piece of equipment saves money in the long run, it should be preferred to one that simply allows more material to be processed. Therefore, when implementing changes to the process you should aim to minimize the EAOC for the new equipment. Remember, when comparing alternatives, all process schemes must be capable of producing a 50% increase in production.

A review by our maintenance department has yielded the following limitations on existing equipment operation and restrictions for any new equipment. These limitations should be used for your study on increasing the capacity of the plant.

1. Maximum long-term cooling water flow through heat exchangers should never exceed 3.0 m/s.
2. If P-601 A/B are operated in parallel, a third pump must be purchased and installed as a back-up.

3. The design pressure of E-602 can be increased to 5.0 bar from 3.5 bar (tube side) without jeopardizing the mechanical integrity of the equipment.
4. All pressure levels of steam (high, medium and low) can be used in the plant. However, only credit for the equivalent savings in natural gas may be taken (assume a 90% boiler efficiency). Note that the cost of boiler feed water for waste heat boilers is negligible due to the condensate return credit from the steam users.
5. Pressure drops for new heat exchangers should be estimated at 0.14 bar for the shell side and 0.34 bar for the tube side. Lower pressure drops can be obtained for exchangers but with an appropriate increase in capital investment. You may assume that pressure drops of 0.07 bar and 0.17 bar for the shell and tube sides, respectively, can be obtained with special design at a cost of 1.5 times the normal cost (as given by CAPCOST[®]).

Assignment

Your assignment is to retrofit the existing Allyl Chloride Facility at Beaumont, TX, (reactor section only) so that a 50% increase (based on the design conditions) in allyl chloride production is possible. Your design should minimize the EAOE of the new equipment required for the retrofit and be consistent with the restrictions outlined above. In addition, you should keep the same ratio of propylene to chlorine at the reactor inlet and the same reactor temperature of 511°C. It has been determined that the selectivity at this temperature is unaffected by pressure.

Your report should consist of the following information.

- (i) A cover letter to your supervisor.
- (ii) An executive summary style report covering the following major points:
 1. Details of your retrofit design to allow the plant to increase production to 150% of design capacity. The technical rationale and logic used to obtain your optimized design should be carefully explained.
 2. Details of all new equipment, e.g., size, installed cost, MOC, etc., should be contained in an equipment summary table.
 3. Economic calculations showing the EAOE for your design (use the same i and n values as given in your first assignment).
 4. A PFD showing all equipment and operating conditions for the 150% of design case.
 5. The effect that recommended changes will have on the health and safety of the plant personnel.
- (iii) A list of assumptions made in carrying out your study.

(iv) An appendix giving details of all important calculations made in your study.

The written report should follow the guidelines outlined in Chapter 22 and the class handouts.

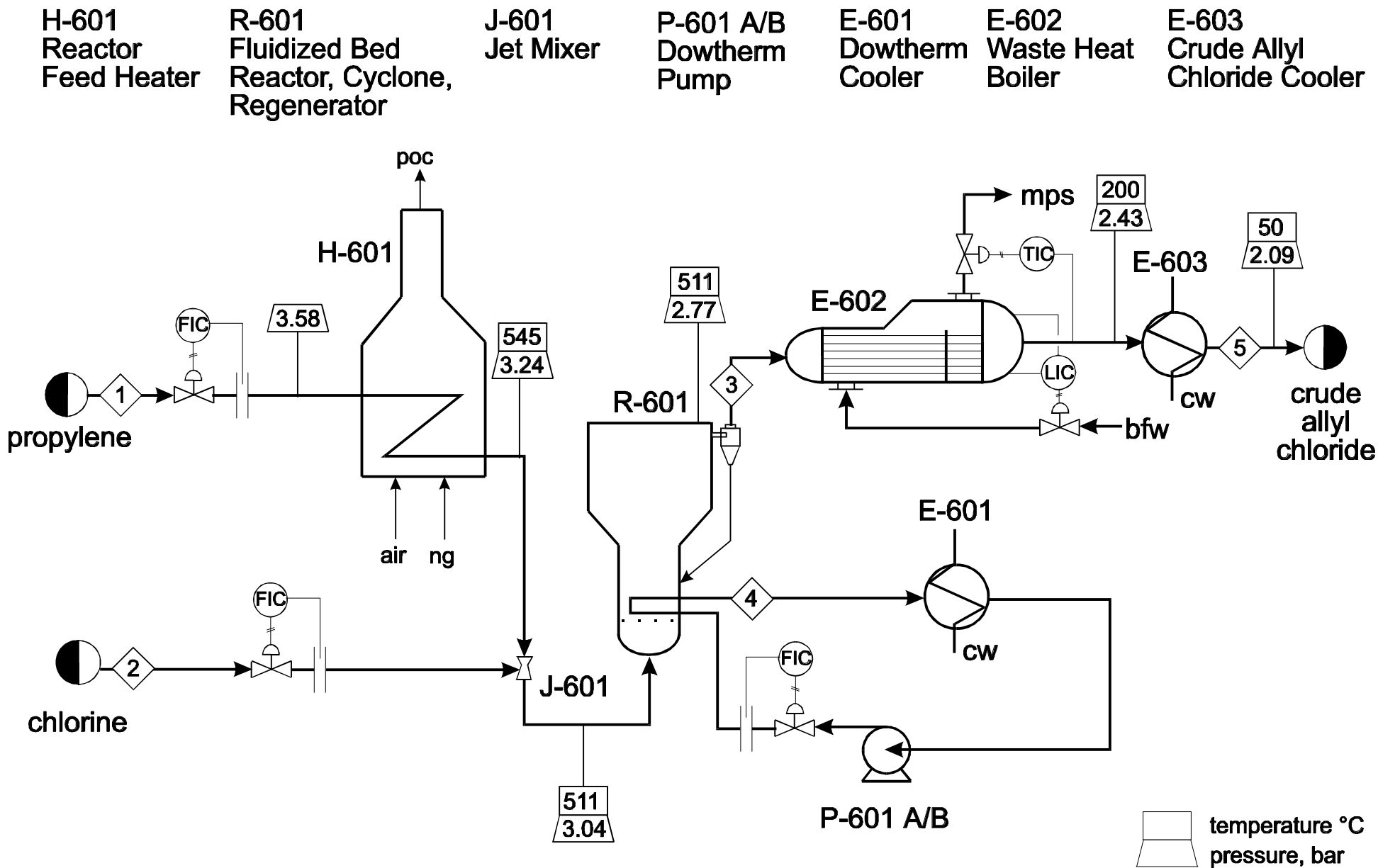

Figure 1: Reaction Section of Allyl Chloride Process