

# **Scale-Down of Phthalic Anhydride Production at STW's Unit 700 – Reaction Section**

## **Background**

You have recently joined the STW Chemical Corporation. One of STW's major businesses has always been production of phthalic anhydride from naphthalene. Phthalic anhydride production is integrated as part of a large chemical plant, in which naphthalene is produced and in which phthalic anhydride is immediately used to make polyester resins. In recent years, there have been some problems. Some end users have complained about the quality of the resins produced, and have taken their business to other companies which produce phthalic anhydride from o-xylene. Therefore, our plant, which had been designed to produce 100,000 metric tons/year of phthalic anhydride from naphthalene was scaled back to about 80,000 metric tons/year several years ago. We are now forced to scale-down production once again, due to the loss of another large customer. Marketing informs us that we may lose additional customers. Research is working on development of catalysts for the o-xylene reaction, but their results are not expected for up to a year. There is an immediate need to determine how to scale-down operation of our plant to 50% of current capacity (40,000 metric tons/year). We would like to accomplish this without a shut-down, since one is not scheduled for a few months. If 50% scale-down cannot be achieved without a shut-down, we need to know how much scale-down is possible immediately. Specifically, you are to determine the maximum possible scale-down, up to 50% of current operating conditions, and you are to define these operating conditions. Furthermore, you are to determine how the plant can be scaled-down to 50% of current capacity, what operating conditions are required, and what capital modifications, if any, are needed. Any suggestions for plant improvements which can be made during shut-down are encouraged. You must clearly define the consequences of any changes that you recommend for this process and the consequences of these changes on other processes which might be affected. It should be noted that one possible scenario is to operate the plant at design capacity for 6 months of the year and shut-down the plant for the remaining 6 months. Although this solution might work, we are reluctant to lay-off our operators for half the year and also to purchase additional storage in order to store enough phthalic anhydride to supply our customers for the 6 months that the plant is down. You should not consider this option any further.

For your first assignment, you are to address the issues described above for the portion of the process before the switch condensers, see Figure 1.

## **Phthalic Anhydride Production**

Unit 700 now produces about 80,000 metric tons/yr of phthalic anhydride. The feeds are essentially pure naphthalene and excess air. These are pressurized, heated and vaporized (naphthalene) and reacted in a fluidized bed with a vanadium oxide on silica gel catalyst. The reactions are:

P-701A/B C-701 H-701 E-701 P-702A/B E-702 P-703A/B SC-701 T-701 E-704 E-705 V-701 P-704A/B T-702 E-706 E-707 V-702 P-705A/B P-705A/B  
 Naphth Feed Air Naphth Air Fluid Molten Molten BFW BFW Maleic Maleic Maleic Phthalic Phthalic Phthalic  
 Feed Furnace Preheater Bed Salt Salt Preheater Bed Salt Salt Preheater Bed Salt Salt Reboiler:Reflux Reboiler:Reflux Reboiler:Reflux  
 Pumps Reactor Cooler Pumps Pumps Pumps Pumps Pumps Pumps Pumps Pumps Pumps Pumps Pumps Pumps Pumps Pumps Pumps Pumps

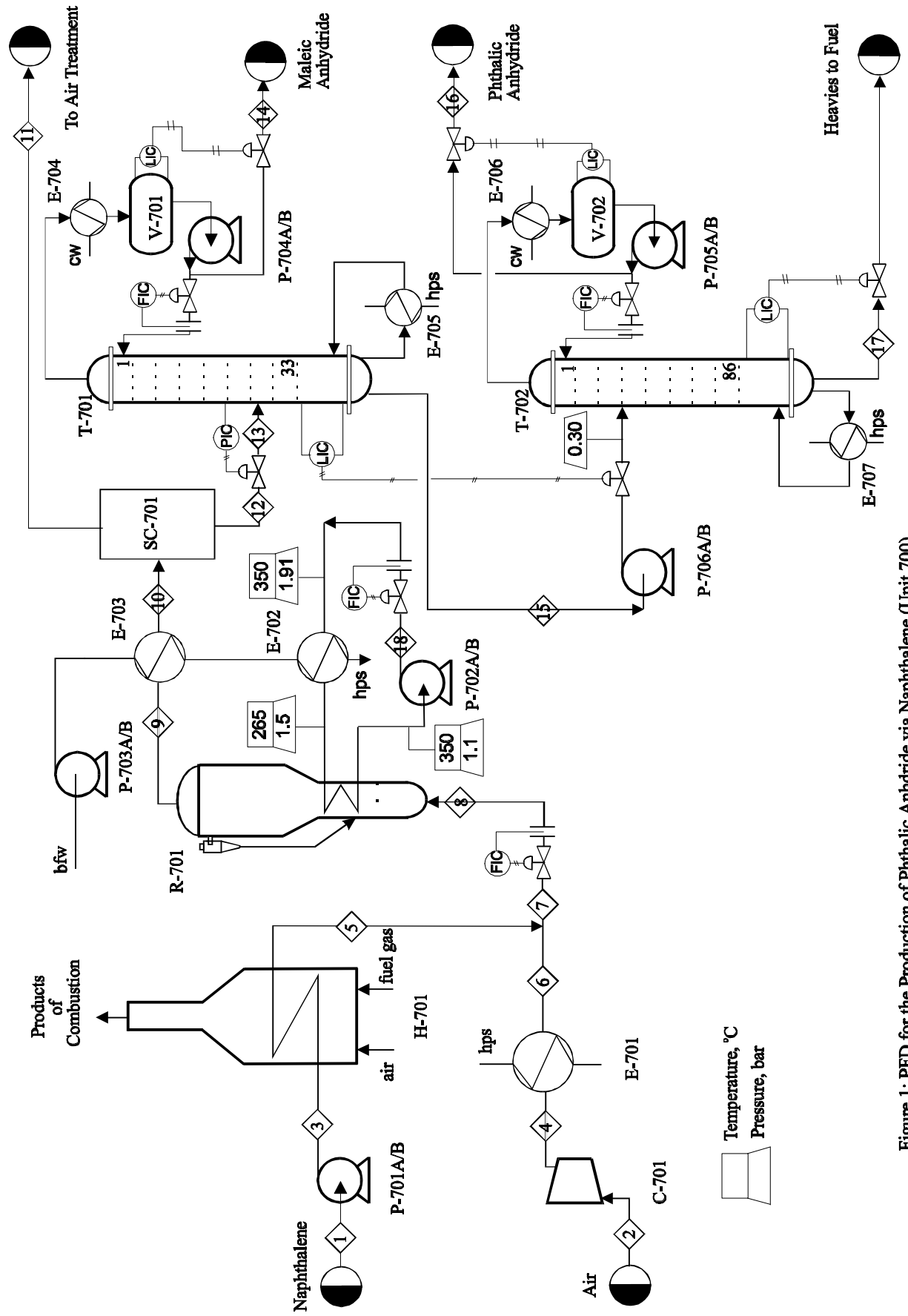
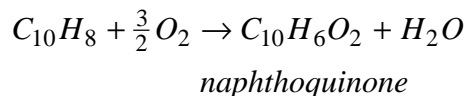
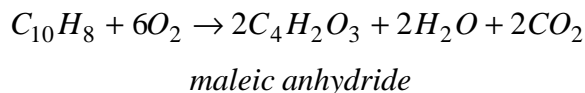
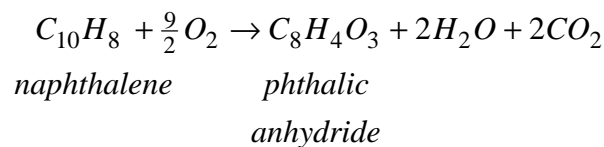

Figure 1: PFD for the Production of Phthalic Anhydride via Naphthalene (Unit 700)



Additionally, the complete and incomplete combustion reactions of naphthalene also occur. The large exothermic heat of reaction is removed by molten salt circulated through coils in the reactor. The molten salt is used to produce high-pressure steam. Total conversion of naphthalene is very close to 100%. The reaction products proceed to a set of devices known as switch condensers. These are described in detail later. Design and operation of these devices is provided under contract by Condensex. They guarantee us that their condensers can operate at any capacity and provide the same separation as in current operation, as long as the pressure and the composition of the condensable portion of Stream 10 remains constant. The net result of the switch condensers is that essentially all of the light gases and water leave as vapor, with small amounts of maleic and phthalic anhydrides, and that the remaining anhydrides and naphthoquinone leave as liquid. The liquid pressure is then reduced to vacuum for distillation. The first column removes maleic anhydride impurity overhead, and the second column removes the phthalic anhydride product overhead.

Organic waste is burned for its fuel value. The dirty air, Stream 11, must be treated. The anhydrides are scrubbed using water, which is then sent to the on-site wastewater treatment facility.

## Other Information

Other pertinent information is appended, including pump and compressor curves, Figures 2 and 3, a flow summary table, Table 1, and an equipment list, Table 2.

## Assignment

Your assignment is to provide recommendations as to how much immediate scale-down is possible, and what, if any, modifications would be needed to scale-down by 50%. For now, you are only to consider the portion of the process prior to the switch condensers. You should also recommend any other changes that you feel should be made to improve performance in Unit 700. Since our plant is due for annual shut-down in a few months, we want specific recommendations as to what should be done at that time, and the cost of these alterations and/or modifications.

Specifically, you are to prepare the following by .... ( two weeks from now)

1. a written report detailing the maximum scale-down possible, how to achieve 50% scale-down, recommendations, and costs associated with scaling-down production in Unit 700
2. a list of new equipment to be purchased, including size, cost, and materials of construction
3. an analysis of any change in the annual operating cost created by your recommended modifications
4. a legible, organized set of calculations justifying your recommendations, including any assumptions made

### **Report Format**

This report should be brief. Most of the report should be an executive summary, not to exceed five double-spaced, typed pages, which summarizes your diagnosis, recommendations, and rationale. Figures and tables may be included (do not count against page limit) in the executive summary. An appendix should be attached which includes items such as the requested calculations. These calculations should be easy to follow. In general, the written report should follow the guidelines given in Chapter 22 of your text [1].

### **References**

1. Turton, R., Bailie, R.C., Whiting, W.B., and J.A. Shaeiwitz, Analysis, Synthesis, and Design of Chemical Processes, Prentice-Hall, Upper Saddle River, NJ, 1998.

**Table 1: Flow Summary Table for Current Operation of Phthalic Anhydride  
Production Facility , Unit 700, see Figure 1.**

Stream No	1	2	3	4	5	6	7	8	9	10
Temperature (°C)	200	25	200	164	400	240	263	263	360	160
Pressure (bar)	0.80	1.01	3.35	3.10	2.85	2.85	2.75	2.25	2.00	1.70
Vapor mole fraction	0.0	1.0	0.0	1.0	1.0	1.0	1.0	1.0	1.0	1.0
Flowrate (tonne/h)	12.82	144.25	12.82	144.25	12.82	144.25	157.07	157.07	157.07	157.07
Flowrate (kmol/h)										
Naphthalene	100.	-	100.	-	100.	-	100.	100.	-	-
Oxygen	-	1050.	-	1050.	-	1050.	1050.	1050.	469.	469.
Phthalic Anhydride	-	-	-	-	-	-	-	-	70.	70.
Maleic Anhydride	-	-	-	-	-	-	-	-	16.	16.
Naphthoquinone	-	-	-	-	-	-	-	-	2.	2.
Carbon Dioxide	-	-	-	-	-	-	-	-	306.	306.
Carbon Monoxide	-	-	-	-	-	-	-	-	50.	50.
Nitrogen	-	3950.	-	3950.	-	3950.	3950.	3950.	3950.	3950.
Water	-	-	-	-	-	-	-	-	238.	238.
Total (kmol/h)	100.	5000.	100.	5000.	100.	5000.	5100.	5100.	5101.	5101.

Stream No	11	12	13	14	15	16	17	18
Temperature (°C)	131	131	131	141	241	190	241	350
Pressure (bar)	1.40	1.40	0.15	0.11	0.30	0.05	0.20	3.00
Vapor mole fraction	1.0	0.0	0.0	0.0	0.0	0.0	0.0	0.0
Flowrate (Tonne/h)	145.00	12.07	12.07	1.61	10.47	10.06	0.40	1624.72
Flowrates in kmol/h								HiTec™ Molten Salt
Naphthalene	-	-	-	-	-	-	-	-
Oxygen	469.	-	-	-	-	-	-	-
Phthalic Anhydride	0.7	69.	69.	0.69	69.	68.	0.69	-
Maleic Anhydride	0.8	15.	15.	15.	0.015	0.015	-	-
Naphthoquinone	-	2.	2.	0.08	1.9	0.002	1.91	-
Carbon Dioxide	306.	-	-	-	-	-	-	-
Carbon Monoxide	50.	-	-	-	-	-	-	-
Nitrogen	3950.	-	-	-	-	-	-	-
Water	238.	-	-	-	-	-	-	-
Total kmol/h	5014.	86.	86.	16.	71.	68.	2.6	17660

**Table 1: Flow Summary Table for Current Operation of Phthalic Anhydride  
Production Facility - Utility Flows, Unit 700 , see Figure 1 (cont'd)**

Stream No.	hps to E-701	conden. from E-701	hps to E-707	conden. from E-707	hps to E-705	conden. from E-705	cw to E-706	cwr from E-706	cw to E-704	cwr from E-704	bfw to E-703	bfw to E-702	hps from E-702
Temperature (°C)	254	254	254	254	254	254	30	45	30	45	91	173	254
Pressure (bar)	42.4	42.4	42.4	42.4	42.4	42.4	5.16	4.86	5.16	4.86	42.4	42.4	42.4
Vapor mole fraction	1.0	0.0	1.0	0.0	1.0	0.0	0.0	0.0	0.0	0.0	0.0	0.0	1.0
Total tonnes/h	6.73	6.73	9.36	9.36	1.89	1.89	267.84	267.84	19.62	19.62	104.98	104.98	104.98

**Table 2: Equipment Summaries (Unit 700)**

**Compressor** (assume efficiency independent of flowrate)

C-701 centrifugal, 5670 kW, 80% efficient @ design flowrate and 3500 rpm can operate at two discrete rpm values, as shown on compressor curve surge line also shown on compressor curve

**Pumps** (assume efficiency independent of flowrate)

P-701 A/B centrifugal, 1.3 kW, 50% efficient

P-702 A/B centrifugal, 54 kW, 70% efficient

P-703 A/B centrifugal, 140 kW, 80% efficient

P-704 A/B centrifugal, 0.5 kW, 40% efficient

P-705 A/B centrifugal, 4.4 kW, 50% efficient

P-706 A/B centrifugal, 0.8 kW, 40% efficient

**Fired Heater** (process fluid flows through a set of tubes with a natural gas or liquid fuel fired flame providing the radiant and convective heat transfer necessary to heat the fluid to the desired temperature.)

H-701 fired heater,  $Q = 9,350$  MJ/hr

consists of four identical banks of tubes - currently these are all in operation, and are operating in parallel - piping and valving exist to run any or all tube banks in any configuration (i.e., series, parallel, etc.) - there is a control system which maintains the temperature of Stream 5 by measuring the temperature of Stream 5 and altering the natural gas and air feed rate.

**Heat Exchangers** (all one pass on each side, unless otherwise noted;  $h_i$  refers to tube side; tube wall resistance negligible, unless otherwise noted)

E-701 uses high pressure steam, steam in shell,  $Q = 11,370$  MJ/hr  
 $A = 695$  m<sup>2</sup>,  $U = 112$  W/m<sup>2</sup>°C,  $h_i = 114$  W/m<sup>2</sup>°C

E-702 makes high pressure steam, steam in shell,  $Q = 216,720$  MJ/hr  
 $A = 539$  m<sup>2</sup>,  $U = 2,840$  W/m<sup>2</sup>°C,  $h_i = 3,960$  W/m<sup>2</sup>°C  
hps supplies Unit 700 needs, excess steam used in Unit 300

**Table 2: Equipment Summaries (Unit 700, cont'd)**

- E-703 preheats high pressure bfw, bfw in shell,  $Q = 36,900$  MJ/hr  
 $A = 1519$  m<sup>2</sup>,  $U = 57$  W/m<sup>2</sup>°C,  $h_i = 63$  W/m<sup>2</sup>°C
- E-704 total condenser for T-701, condensing fluid in shell  
 $A = 5.52$  m<sup>2</sup>,  $U = 600$  W/m<sup>2</sup>°C, all resistance on water side
- E-705 reboiler for T-701  
 $A = 50$  m<sup>2</sup>,  $U = 1,400$  W/m<sup>2</sup>°C, approximately equal resistances
- E-706 total condenser for T-702, condensing fluid in shell  
 $A = 51$  m<sup>2</sup>,  $U = 600$  W/m<sup>2</sup>°C, all resistance on water side
- E-707 reboiler for T-702  
 $A = 243$  m<sup>2</sup>,  $U = 1,400$  W/m<sup>2</sup>°C, approximately equal resistances

### **Reactor**

The reactor is a fluidized bed which means that the bed temperature is essentially constant and equal to the exit temperature of the gas.

- R-701 fluidized bed with vanadium oxide catalyst coated on silica gel  
molten salt circulated in tubes to remove heat of reaction  
heat exchange area = 15,850 m<sup>2</sup> (parallel tube banks within reactor)  
 $U = 100$  W/m<sup>2</sup>°C, all resistance on reactor side  
heat removal required =  $2.154 \times 10^5$  MJ/hr  
reactor pressure drop unaffected by flow rate

### **Molten Salt Loop**

Molten salt is used to remove the heat generated in the reactor. It circulates in a closed loop, and is thermally regenerated by making high-pressure steam in E-702. The properties of this molten salt, known as HiTec™, may be found in the 6th edition of Perry's handbook, page 9-77.



**Table 2: Equipment Summaries ( Unit 700, cont'd)**

**Switch Condenser**

SC-701 There are three sets of condensers. Due to the low partial pressure of phthalic anhydride in the stream, it desublimates rather than condenses. Therefore, the process stream is cooled using a low temperature oil in tubes to promote desublimation. Then, after solid is loaded on the heat transfer surface, higher temperature oil is circulated in the tubes to melt the solid. There are three such devices, one operating in desublimation mode, one operating in melting mode, and one on standby. The net result is a liquid stream containing the condensables, and a vapor stream containing water and the non-condensables. These condensers are designed and maintained under contract by Condensex. They indicate operation at any scale is possible as long as the pressure of Stream 10 remains within 10% of current operating conditions, and as long as the relative composition of the condensables remains approximately constant.

**Distillation Columns** (For both distillation columns, it may be assumed that weeping begins to occur at 35% of flooding. Both use high pressure steam and cooling water at the maximum allowable temperature rise.)

T-701 removes maleic anhydride impurity overhead  
reflux ratio = 0.27  
33 trays, 40% efficient, 12 in tray spacing, 2 in weirs  
diameter = 0.84 m, active area = 75% of total area  
 $Q_c = -1230$  MJ/hr  
 $Q_r = 3220$  MJ/hr

T-702 removes phthalic anhydride product overhead  
reflux ratio = 2.43  
86 trays, 50% efficient, 18 in tray spacing, 0.75 in weirs  
diameter = 4.2 m, active area = 75% of total area  
 $Q_c = -16,810$  MJ/hr  
 $Q_r = 15,890$  MJ/hr

**Vessels**

V-701 Diameter = 0.50 m, Length = 1.50 m

V-702 Diameter = 1.25 m, Length = 3.75 m

## **Air Treatment**

The organics in Stream 11 are removed in a scrubber, with 10,000 kg of water needed per kg of organic, at the current operating conditions. If the organic content of Stream 11 becomes more concentrated, then the amount of water needed increases by 100 kg per 0.001 mass fraction of organic. The water is sent to the on-site waste-water treatment facility.

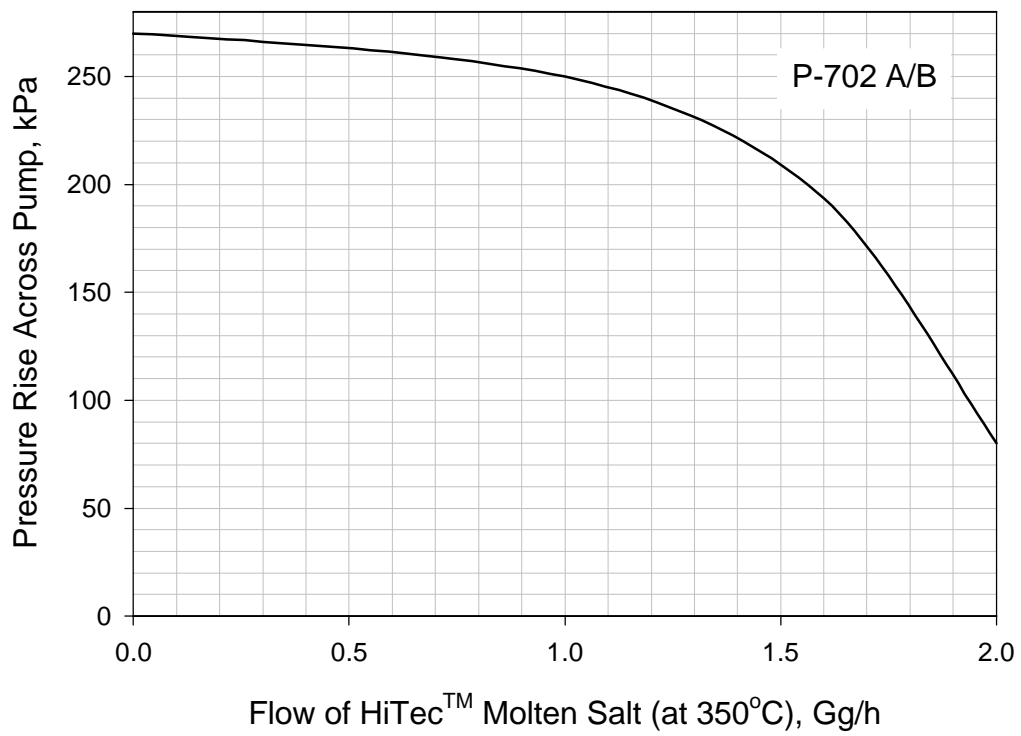
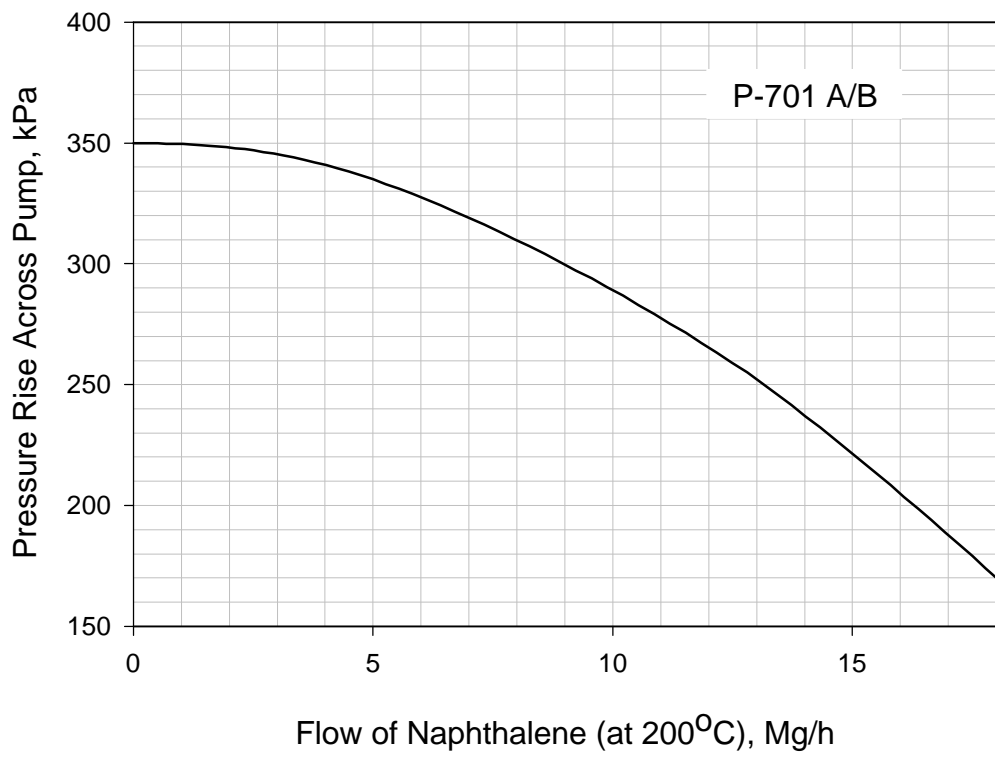

Figure 2: Pump Curves for P-701 A/B and P-702 A/B

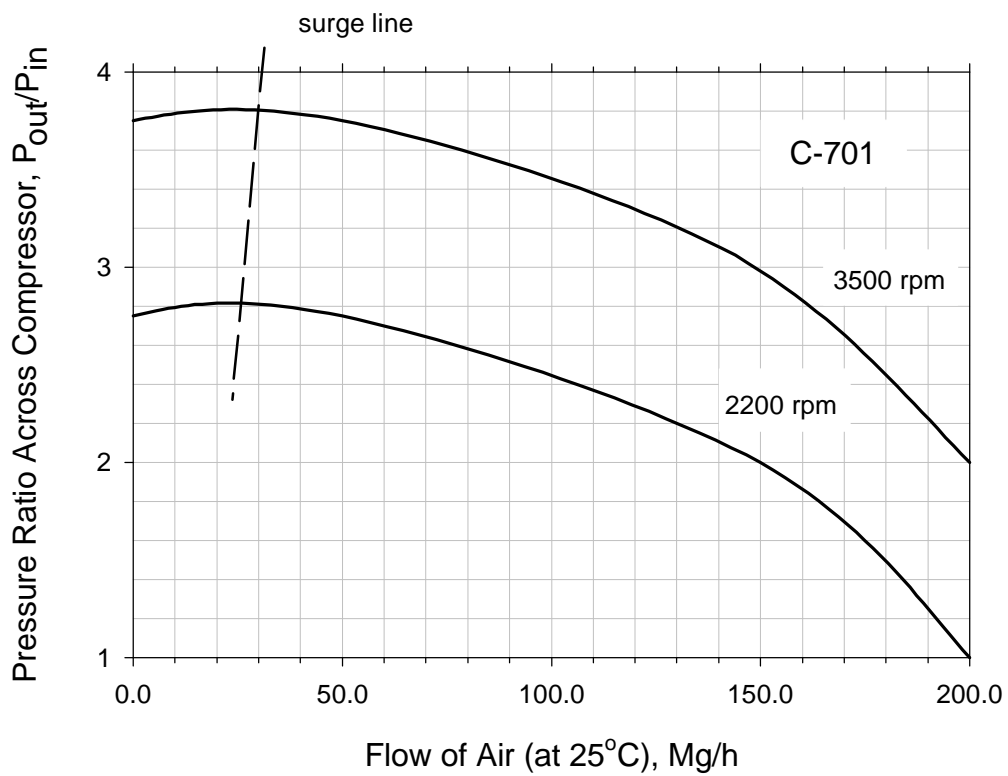
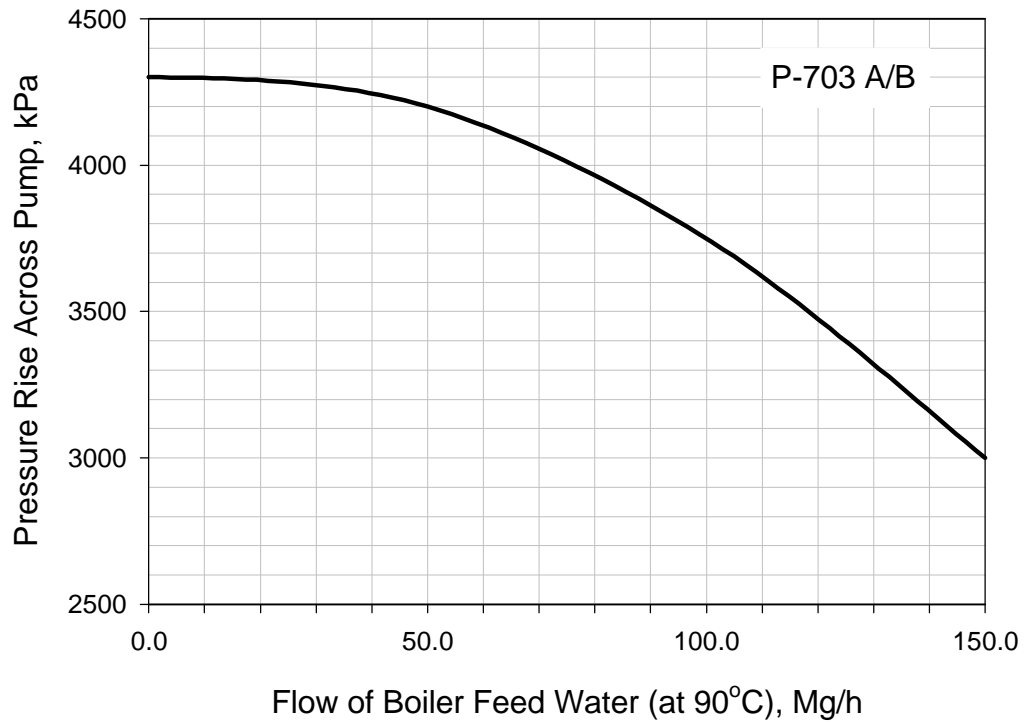

Figure 3: Pump and Compressor Curves for P-703 A/B and C-701